

**SEAT & FRAMING PLAN**

1/4" = 1'-0"  
42 NET SEATS @ 18" PER SEAT

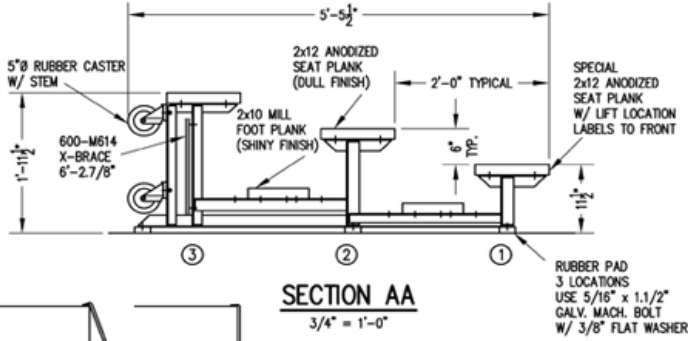

**SECTION AA**

3/4" = 1'-0"



- 1) LOCATE THE CHANNEL END CAP AS SHOWN IN FIG. 1.
- 2) TAP END CAP INTO PLACE WITH RUBBER Mallet OR SOFT WOOD. FIG. 2
- 3) DRILL TWO 5/32" HOLES THROUGH THE BOTTOM FLANGE AND THE BOTTOM OUTSIDE PLANK FLANGES. INSTALL TWO 3/16" DRIVE RIVETS. (2 PER PLANK)

**END CAP DETAIL**

N.T.S.



**X-BRACE DETAIL**

N.T.S.

- 7/16" x 1" GALV. MACH. BOLT
- △ 7/16" x 1.1/2" GALV. MACH. BOLT

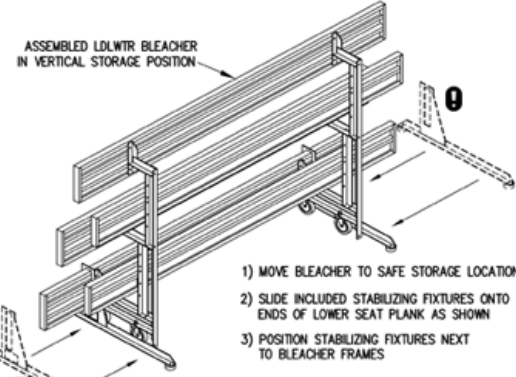

**VERTICAL STORAGE OF BLEACHER WHEN REQUIRED**

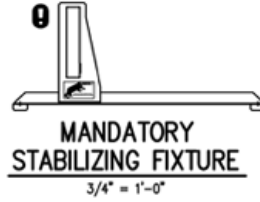

STABILIZING FIXTURE - ONE REQUIRED FOR EACH END OF BLEACHER

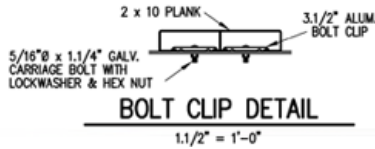

**BOLT CLIP DETAIL**

1.1/2" = 1'-0"

**TIP & ROLL 21L**